

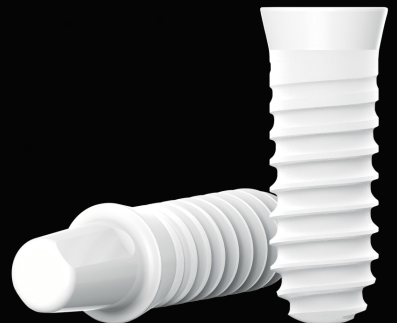

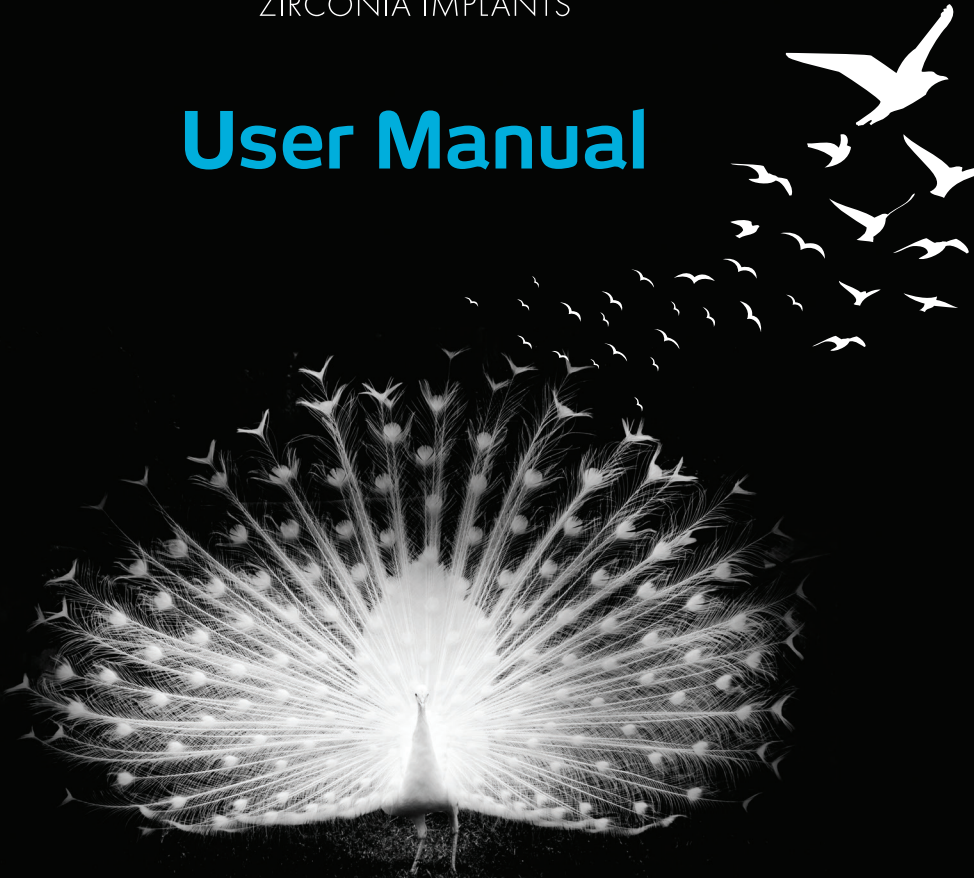







ZIRCONIA IMPLANTS

# User Manual



**TAVDental**  
PRECISION. PASSION. PARTNERSHIP

## Zirconia Advantages

-  Highly Esthetic Results
-  Biocompatibility
-  High Strength and Mechanical Properties
-  Healthy Looking Soft Tissues
-  No Discoloration of Soft Tissues
-  Osseointegration Comparable with Titanium Implants
-  Excellent Alternative to Titanium Implants
-  Long-Term Health Improvement

## Surface

W Zirconia implants rough surface topography combines micro and macro roughness, ensuring reliable osseointegration.

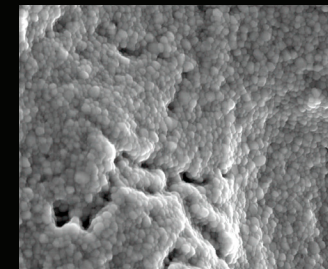
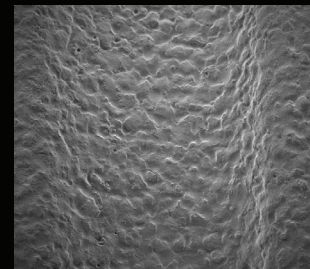

## Planning Guidelines

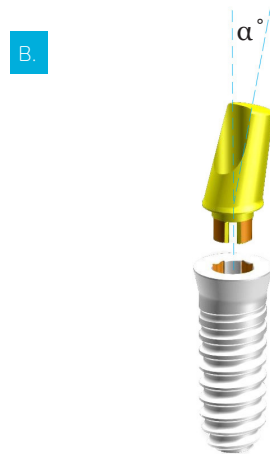
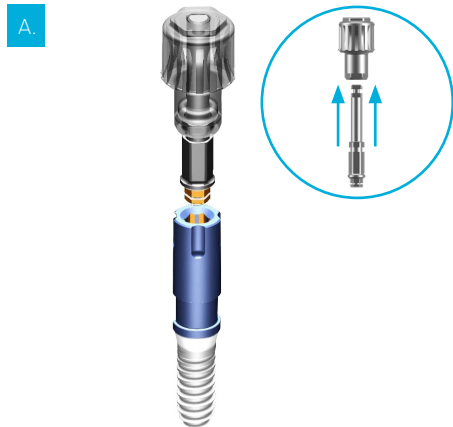

 Grinding or altering any part of the implant or abutment is strictly prohibited. Grinding or altering may lead to micro-cracks which may result in implant failure.

## Healing Phase





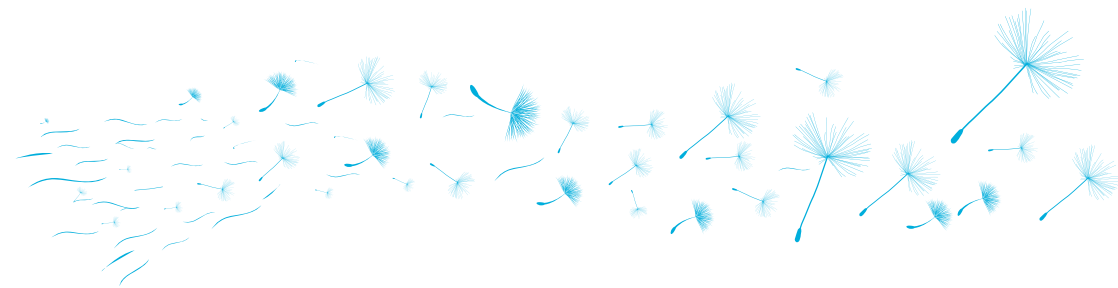

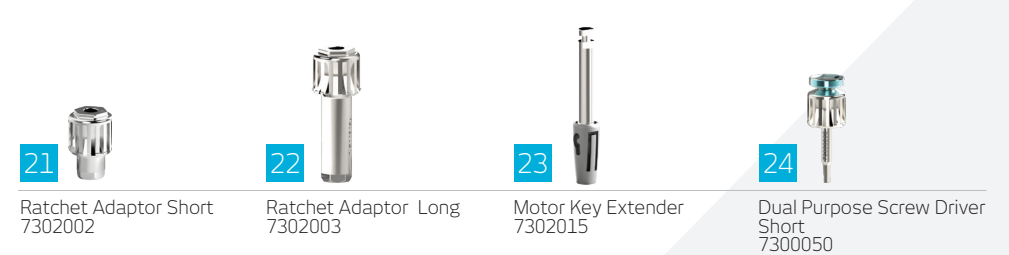
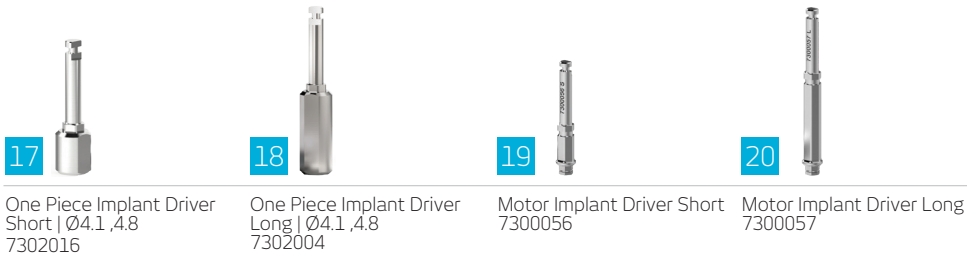
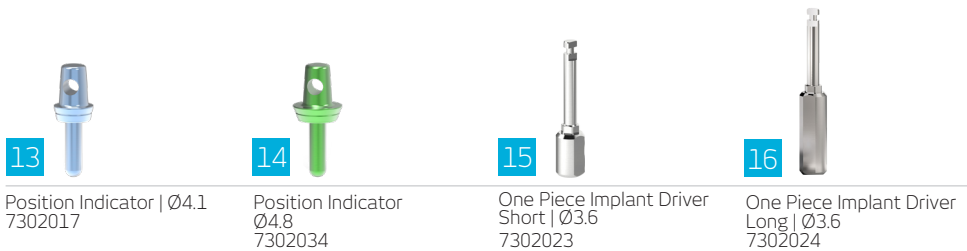
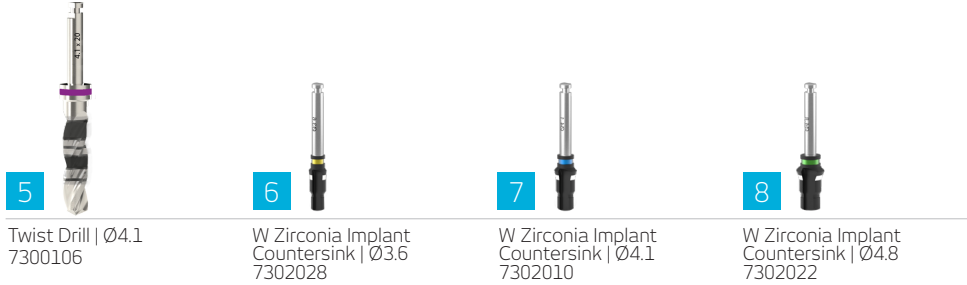

Situation	Healing Phase
<ul style="list-style-type: none"> <li>Good bone quality and adequate bone quantity.</li> </ul>	<ul style="list-style-type: none"> <li>▶▶ Minimum 6 weeks.</li> </ul>
<ul style="list-style-type: none"> <li>Cancellous bone quality.</li> </ul>	<ul style="list-style-type: none"> <li>▶▶ Minimum 12 weeks.</li> </ul>
<ul style="list-style-type: none"> <li>For all other conditions, such as bone augmentation or incomplete contact with the bone.</li> </ul>	<ul style="list-style-type: none"> <li>▶▶ A period of 3-6 months should be allowed for adequate bone healing following any required augmentation.</li> </ul>

The healing time for osseointegration may vary. It is the physician responsibility to make a decision regarding the implant loading.







## Drilling Sequence

Catalog No.	Description	Ø3.6	Ø4.1	Ø4.8	Speed [rpm]
7300001	 Precision Drill	✓	✓	✓	800
7300002	 Pilot Drill   Ø2.0	✓	✓	✓	800
7300062	 Twist Drill   Ø2.8	✓	✓	✓	600
7302005	 Twist Drill   Ø3.4	—	✓	✓	500
7300106	 Twist Drill   Ø4.1	—	—	✓	400
7302028	 Countersink Ø3.6	✓	—	—	300 (Max)
7302010	 Countersink Ø4.1	—	✓	—	300 (Max)
7302022	 Countersink Ø4.8	—	—	✓	300 (Max)

 When use countersink consider bone type and desire implant shoulder level.

## Tapping Sequence

Tapping sequence gives the surgeon the flexibility to adjust the surgical protocol to the bone type.

Catalog No.	Description	D1	D2	D3	D4	Speed [rpm]
7302027	Ø3.6 	✓	○	—	—	15 (Max)
7302007	Ø4.1 	✓	○	—	—	15 (Max)
7302021	Ø4.8 	✓	✓	✓	✓	15 (Max)

 Thread tapping over full depth of the implant site

 Thread tapping in the coronal area of the implant site

— Do not use



# Two Piece

# 2Piece Zirconia Implant

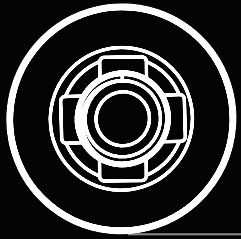

The Slot connection geometry optimizes the force transfer applied on the implant connection during insertion and as a result allows to simplify the implant placement procedure.



Built-in emergence profile at the soft tissue level



1.8mm neck allowing trans-or subgingival healing

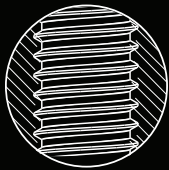

2piece implant for screw retained restorations



Rough surface topography combines micro and macro roughness



Thread pitch 1mm



**!** Grinding or altering any part of the implant is strictly prohibited. Grinding or altering may lead to micro-cracks which may result in implant failure.

# 2Piece Zirconia Implant

Ø4.1 IMPLANT	7102042	7102043	7102044	7102040
--------------	---------	---------	---------	---------

Ø4.8 IMPLANT	7102045	7102046	7102047	7102041
--------------	---------	---------	---------	---------

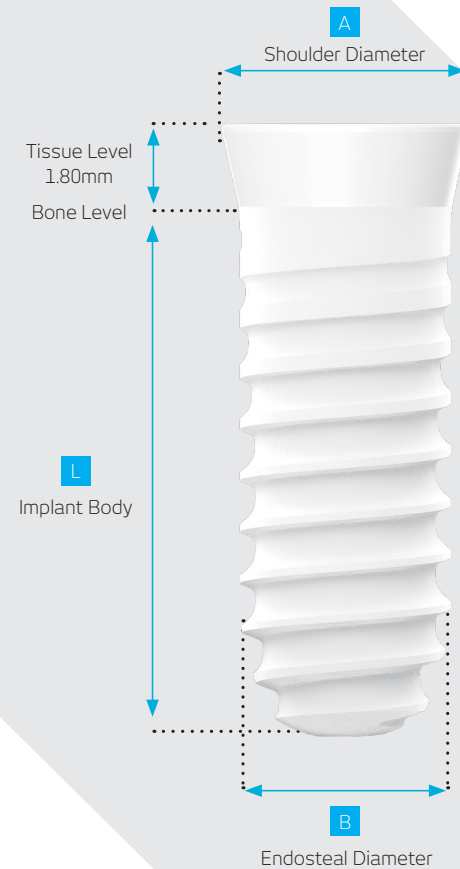
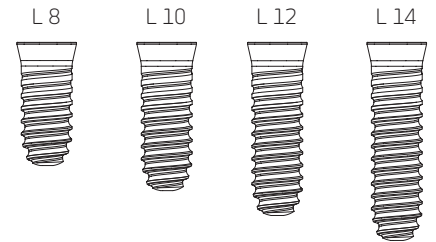

COVER SCREW



Ø4.1      Ø4.8

\* Supplied with W Two piece implant.

	<b>A</b>	<b>B</b>	<b>L</b>
Ø4.1 IMPLANT	Ø4.80	Ø4.10	8, 10, 12, 14
Ø4.8 IMPLANT	Ø6.00	Ø4.80	8, 10, 12, 14

## 2Piece Implant Packaging System

The packaging system of TAV Dental implants includes external implant packaging, sealed tube and sterile mini tube as well as additional contents. The sealed tube [9] provides bacterial/sterile barrier maintaining its inner volume (mini tube [8] and implant [6]) sterile throughout the product shelf life resulting with a complete sterile packaging system.

The content of the package is identified below:

- |                                |                              |
|--------------------------------|------------------------------|
| 1. External Implant Packaging  | 6. W 2Piece Zirconia Implant |
| 2. Instruction for Use Leaflet | 7. Support Ring              |
| 3. Cover Cap                   | 8. Sterile Mini Tube         |
| 4. Cover Screw                 | 9. Sealed Tube               |
| 5. Insertion Tool              | 10. 3 Patient Labels         |



Each package is identified with the implant outer diameter and length dimensions. The outer diameter is also represented by a color code.



The sealed tube serves as bacterial/sterile barrier assuring the sterility of the mini tube, which contains the implant. Do not use the implant if the sealed tube is opened or damaged.

Please Note: TAV Dental's sealed tube functions as sterile blister as used in some other implant packaging systems and serves as full bacterial/sterile barrier.



## 2Piece Implant Packaging Removal

Step 1



Take the external implant package.

Step 2



Remove the bottom cap of the external implant package.

Step 3



Take out the product IFU and 3 patient labels.

Step 4



Take the sealed tube out of the external package.

The sealed tube ensures the sterility of the sterile mini tube which contains the implant. Do not open the sealed tube until immediately before the implant placement.

Step 5



Open the sealed tube, which contains the sterile mini tube.



## 2Piece Implant Packaging Removal

Step 6

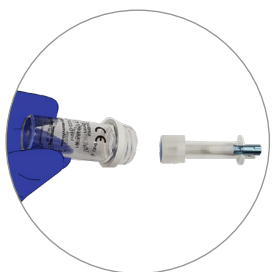

Pour the sterile mini tube containing the sterile implant directly into the aseptic field.

Step 7

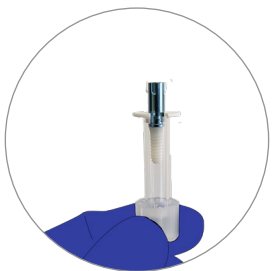

Pull out the cover cap containing the cover screw and put it aside on an aseptic field. The cover screw will be used in [Step 4](#) of Implant Insertion Instructions below, on page 14.

Step 8



Connect the Ratchet Adaptor and motor tool to the insertion tool and pull it out from the sterile mini tube while the implant is still connected to the insertion tool and the support ring.

Step 9

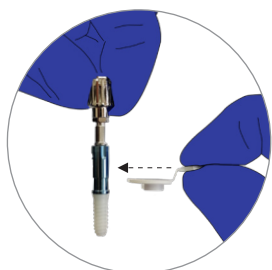

Pull out the support ring horizontally.

Step 10



Place the implant into the implant bed, according to the implant insertion instructions specified in [Steps 1-4](#) on page 14, '2Piece Implant Insertion'.

## 2Piece Implant

The implant is a tissue level implant. The wide diameter of the implant should be 1.8mm above the bone level (see illustration).

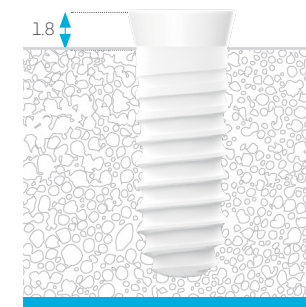

**!** Please pay attention to the specified torque limits:

	Speed [rpm]	Recommended torque [N-cm]	Max. torque allowed [N-cm]
⚠ TISSUE LEVEL ZIRCONIA IMPLANT	15	35	60
⚠ ZIRCONIA IMPLANT COVER SCREW	N/A	15	N/A



## 2Piece Implant Insertion

Step 1

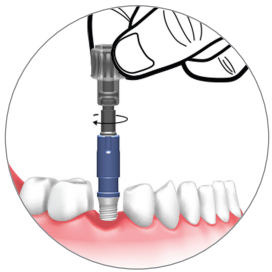

Begin placing the implant manually.

Step 2



Use either a Ratchet Adaptor and motor tool with torque ratchet, or a motor tool with hand piece to fully insert the implant to the implantation site, make sure not to exceed the torque specified limits.

Step 3

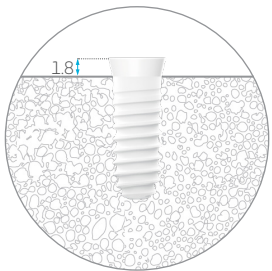

Implantation is completed when the implant is positioned 1.8mm above the bone level.

Step 4

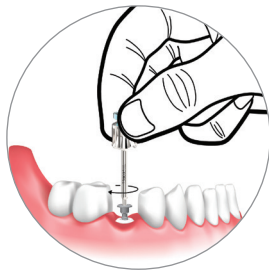

Remove the cover screw from the bottom cap using a Dual Purpose Screw Driver Long (7300051) and screw it manually into the implant. Use the torque ratchet to fully insert the cover screw, make sure not to exceed the torque specified limits. Suture the gingiva over the cover screw.

## TL Zirconia Implant Abutments

### TL Zirconia Implant Abutments for Bridge



0°

7202044

### TL Zirconia Implant Abutments



0°

7202040



5°

7202041



10°

7202042



15°

7202043

*An angled abutments are not to be placed in the molar region*



The Abutments are supplied non-sterile, to be sterilized by the physician before use see IFU 7900154. Abutments Recommended Tightening Torques 30N-cm.



## Healing Cap for 2Piece Implant

	PEEK Healing Cap		Titanium Healing	
	Ø4.1	Ø4.8	Ø4.1	Ø4.8
H1mm	7202046	7202050	7202068	7202072
H2mm	7202047	7202051	7202069	7202073
H3mm	7202048	7202052	7202070	7202074
H4mm	7202049	7202053	7202071	7202075



	Ø4.1	Ø4.8	Ø4.1	Ø4.8
H1mm	7202046	7202050	7202068	7202072
H2mm	7202047	7202051	7202069	7202073
H3mm	7202048	7202052	7202070	7202074
H4mm	7202049	7202053	7202071	7202075

The healing caps are supplied non-sterile, to be sterilized by the physician before use, see IFU 7900154.

## Prosthetic Procedure for Healing Cap

- Step 1** Ensure the internal configuration of the implant is clean and bloodless.
- Step 2** Insert the healing abutment onto the implant.
- Step 3** Tighten the Healing abutment onto the implant to 15 N.cm using Ratchet torque.
- Step 4** Adapt the soft tissue and suture it back tightly around the abutment.
- Step 5** Remove after the healing phase completed, no later than 180 days.

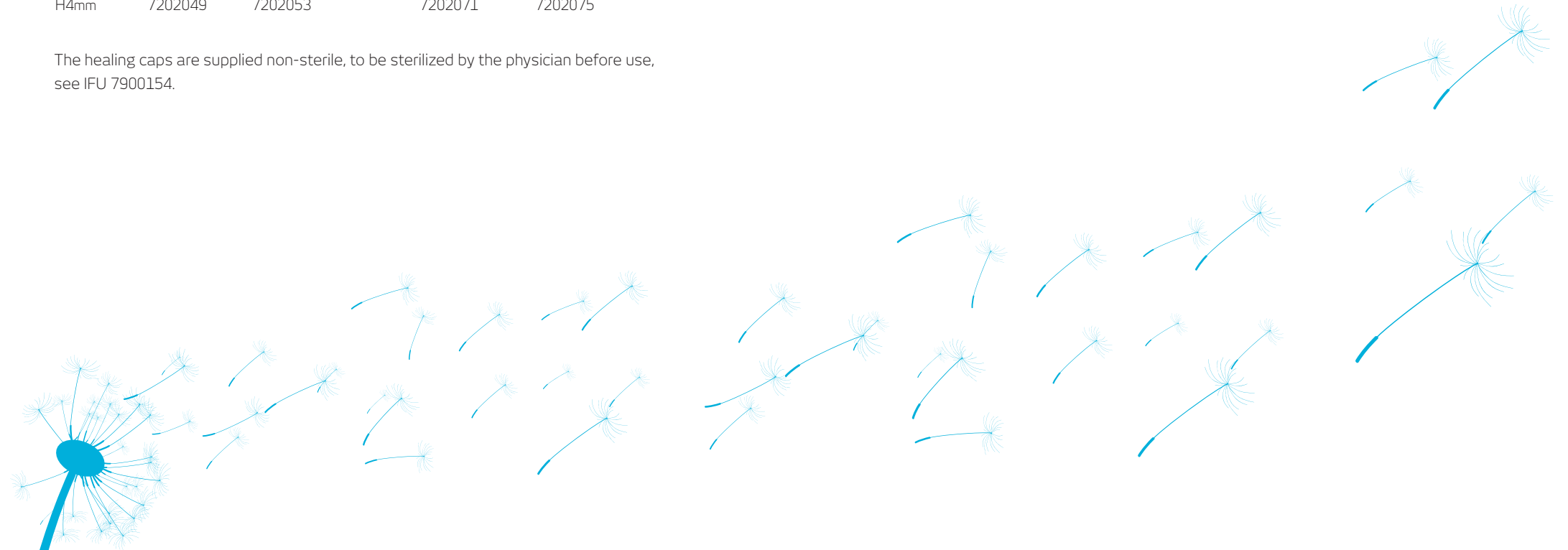

## Open Tray Impression

### Implant Analog

Ø4.1 7202054

Ø4.8 7202055



### Implant Open Tray

7202076



## Open Tray Technique for 2Piece Implant

- Step 1** Remove the healing cap after the healing phase.
- Step 2** Connect the implant transfer (7202076) to the implant with a fixation screw.
- Step 3** Prior to impression taking make sure the holes are positioned accurately and the transfer can penetrate through the holes.
- Step 4** Take the impression using silicone impression material. Make sure the transfer screw extend through the hole.
- Step 5** Remove the fixation screw to uncouple the transfer and remove the impression tray.
- Step 6** Connect the relevant implant analog to the transfer on the impression tray.
- Step 7** Use the final impression to create master cast model.



One  
Piece

# One Piece Zirconia Implant

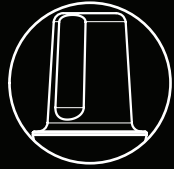

One piece design with integrated abutment



Built-in emergence profile at the soft tissue level



1.8mm neck



Rough surface topography combines micro and macro roughness



Thread pitch 1mm

 Grinding or altering any part of the implant or abutment is strictly prohibited. Grinding or altering may lead to micro-cracks which may result in implant failure.

# One Piece Zirconia Implant

Ø3.6 IMPLANT	7102050	7102051	7102052	7102037
Ø4.1 IMPLANT	7102028	7102029	7102030	7102038
Ø4.8 IMPLANT	7102034	7102035	7102036	7102039

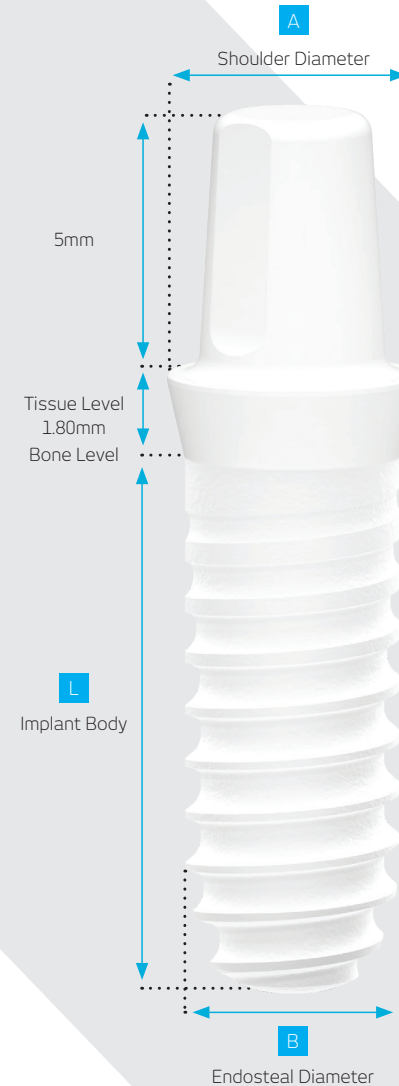
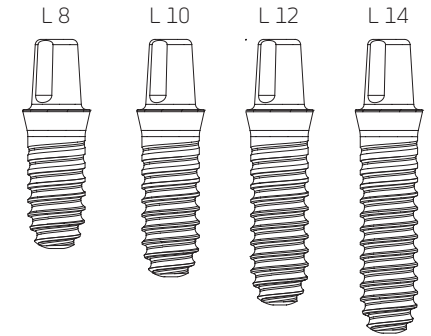

	A	B	L
Ø3.6 IMPLANT	Ø3.80	Ø3.60	8, 10, 12, 14
Ø4.1 IMPLANT	Ø4.80	Ø4.10	8, 10, 12, 14
Ø4.8 IMPLANT	Ø6.00	Ø4.80	8, 10, 12, 14

## One Piece Packaging System

The packaging system of TAV Dental implants includes external implant packaging, sealed tube and sterile mini tube as well as additional contents. The sealed tube [8] provides bacterial/sterile barrier maintaining its inner volume (mini tube [7] and implant [5]) sterile throughout the product shelf life resulting with a complete sterile packaging system.

The content of the package is identified below:

1. External Implant Packaging
2. Instructions for Use Leaflet
3. Cover Cap
4. Implant Holder
5.  One Piece Zirconia Implant
6. Support Ring
7. Sterile Mini Tube
8. Sealed Tube
9. 3 Patient Labels



Each package is identified with the implant outer diameter and length dimensions. The outer diameter is also represented by a color code.



The sealed tube serves as bacterial/sterile barrier assuring the sterility of the mini tube, which contains the implant. Do not use the implant if the sealed tube is opened or damaged.

Please Note: TAV Dental's sealed tube functions as sterile blister as used in some other implant packaging systems and serves as full bacterial/sterile barrier.



## One Piece Packaging Removal

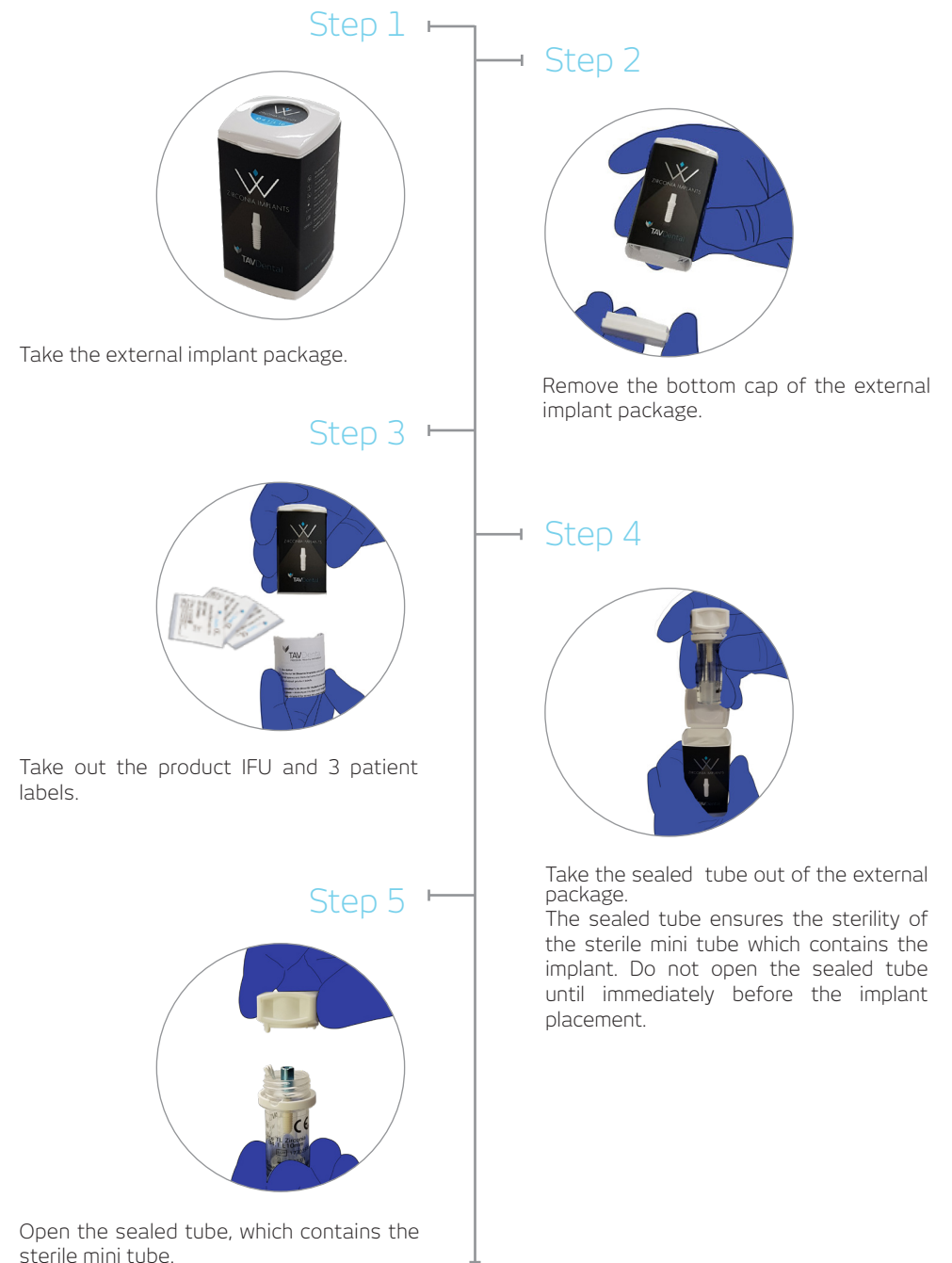

## One Piece Packaging Removal

Step 6



Pour the sterile mini tube containing the sterile implant directly into the aseptic field.

Step 7

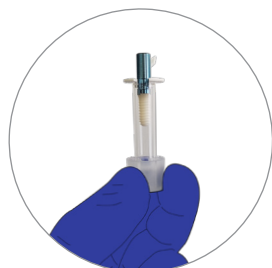

Use new sterile gloves and hold the sterile mini tube face up.

Step 8



Connect the implant driver to the implant holder and pull it out from the sterile mini tube while the implant is still connected to the implant holder and the support ring.

Step 9

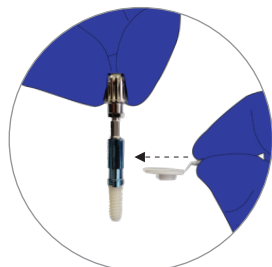

Pull out the support ring horizontally.

Step 10

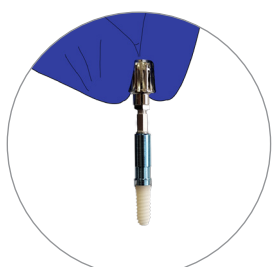

Place the implant into the implant bed according to [Steps 1-3](#) described on page 25, One Piece Implant Insertion.

## One Piece Implant Insertion

The implant is a tissue level implant. The wide diameter of the implant should be 1.8mm above the bone level (see illustration).

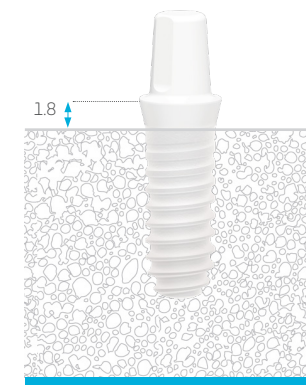

Step 1

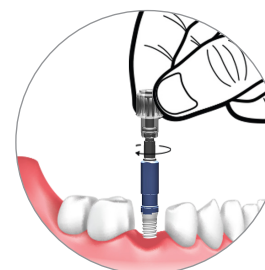

Begin Placing the implant manually, while implant holder still connected.

Step 2

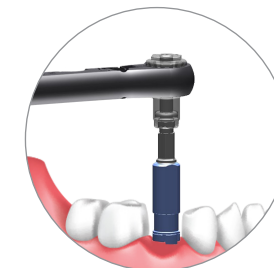

Use either torque ratchet, or a motor tool with hand piece to fully insert the implant to the implantation site, make sure not to exceed the torque specified limits. In case implant holder disassembled from implant before reaching final position, continue implantation without implant holder using motor tool.

Step 3

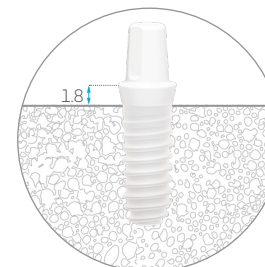

Implantation is completed when the implant is positioned 1.8mm above the bone level.



If maximum torque is achieved before the implant reaches its final position check again the bed preparation.

**!** Please pay attention to the torque limits specified below:

	Speed [rpm]	Recommended torque [N.cm]	Max. torque allowed [N.cm]
ONE PIECE ZIRCONIA IMPLANT	15	35	60

## PEEK Healing Cap

Healing caps are intended to protect the implant during the healing phase and to support the emergence profile. The healing caps also support the emergence profile and keep the implant shoulder ideal for the impression phase.

### PEEK Healing Cap

Ø3.6	7202031
Ø4.1	7202013
Ø4.8	7202028



The healing caps are supplied non-sterile, to be sterilized by the physician before use, see IFU 7900154.

## Prosthetic Procedure for Healing Cap

- Step 1** Ensure the implant integrated abutment is clean and bloodless.
- Step 2** Snap the healing cap onto the implant integrated abutment.
- Step 3** Prepare a protective device using standard technique.
- Step 4** Make sure the protective device is attached to adjacent teeth only and keep a space of minimum 1.5mm between the protective device and the healing cap. Healing caps are used during healing phase only and do not support a restoration.
- Step 5** Remove after the healing phase completed.

⚠ TAV Dental healing caps are indicated to be placed in patients mouth at the end of TAV Dental implant placement for maximum of 180 days.

## PEEK Temporary Cap

### Temporary Cap for Crown

Ø3.6	7202032
Ø4.1	7202016
Ø4.8	7202029



### Temporary Cap for Bridge

Ø3.6	7202033
Ø4.1	7202017
Ø4.8	7202030



## Prosthetic Procedure for Temporary Cap

- Step 1** Snap the temporary cap to the implant integrated abutment.
- Step 2** Mark the appropriate height and shorten the cap as required, make sure the temporary restoration is out of occlusion.
- Step 3** Fabricate the provisional crown according to standard procedure and cement the provisional crown to the cap.
- Step 4** Remove the undercut snap from the cap to allow appropriate excess cement flow.
- Step 5** Apply temporary cement into the cap inner part.
- Step 6** Cement the cap already assembled with the provisional crown to the integrated abutment.
- Step 7** Remove no later than 180 days.

⚠ The Temporary Cap are supplied non-sterile, to be sterilized by the physician before use see IFU 7900154.



## Closed Tray Impression

### Implant Analog

Ø3.6	7202037
Ø4.1	7202011
Ø4.8	7202039



### Implant Plastic Transfer

Ø3.6	7202034
Ø4.1	7202014
Ø4.8	7202036



## Closed Tray Technique for One Piece Implant

- Step 1** Remove the temporary cap after the healing phase.
- Step 2** Snap the relevant plastic transfer to the implant integrated abutment.
- Step 3** Take the impression using silicone impression material. After removing the tray the plastic transfer remains in the impression material.
- Step 4** Snap the relevant implant analog to the transfer which remains on the impression material.
- Step 5** Use the final impression to create master cast model. using standard technique.

Smile,  
you look much  
better



[info@tavdental.com](mailto:info@tavdental.com) | [www.tavdental.com](http://www.tavdental.com)

TAV Dental © All rights reserved

7920048 Rev. A  
Draft